

A ballistic bomb calorimeter

BY D. S. MILLER AND P. R. PAYNE

*Human Nutrition Research Unit, Nutrition Building, National Institute
for Medical Research, Mill Hill, London, N.W. 7*

(Received 9 May 1959—Revised 29 June 1959)

The classical methods for determining the calorie value of foodstuffs are both long and tedious, and a number of alternative methods have been suggested for assessing the energy value of foods based on an analysis of the foodstuff and the use of factors with each of the chemical components to give energy content. None of these methods is really satisfactory, and when a high level of accuracy is required direct calorimetry must be used. An improved method which shortens the time taken for a single determination without loss of accuracy would be clearly of great value.

The adiabatic method used by Raymond, Canaway & Harris (1957) reduced the time taken for a determination to approximately 30 min, but the equipment is complicated and expensive. A fundamental feature of this and the classical procedure is that the quantity of heat produced is measured by a small rise in temperature of a large mass of material, resulting in long equilibration times and the need for great accuracy of temperature measurement. A simple method proposed by Féry (1912) partly overcomes these disadvantages by making use of a light bomb casing of a standard heat capacity and eliminating the water calorimeter. In this way the equilibration time is reduced to 5 min and the temperature rise is increased to 20–30°. In the method now described no attempt is made to measure the equilibrium temperature of the bomb casing; instead, advantage is taken of the fact that on combustion of a sample most of the heat is transmitted to the upper parts of the bomb casing, which thus rapidly (50 sec) warm up to a high temperature (about 70°) and rapidly cool. We have found that the peak temperature is an accurate measure of the heat released, and we have termed this method of measuring heat quantity 'ballistic', by analogy with the ballistic method of measuring electrical quantities.

In an earlier communication (Fox, Miller & Payne, 1959) a commercially available bomb, modified for this technique by attaching a thermocouple to the lid, was described. Though it was satisfactory in operation, it was thought that some improvement in performance would result from a reduction in thermal capacity of the upper parts of the vessel. Also the conventional lid, with its gas inlet, electrode and thermocouple attachments, was difficult to dry after cooling with tap water between determinations.

EXPERIMENTAL AND RESULTS

Description of apparatus

For the reasons stated, a bomb of a new design was produced (manufactured by Thornhill Productions Ltd, 20 Thornhill Road, London, N. 1). Its component parts are illustrated in Fig. 1. The vessel consists of two main parts, and the lower has been drawn in elevation from two directions at right angles. The upper section (*A*), with an internal diameter of 6 cm and height of 10.5 cm, forms the main volume of the bomb and has a small blind hole in the centre of the top, into which the thermocouple is plugged. This top, having a small thermal capacity and a simple shape, can be cooled quickly in running tap water and easily dried.

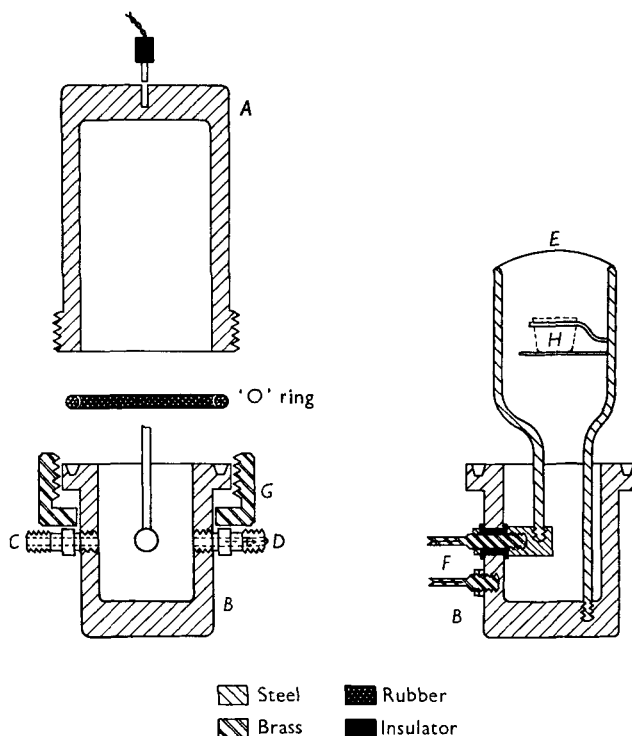

Fig. 1. Diagram of bomb. *A*, upper section of bomb; *B*, lower section of bomb; *C*, oxygen inlet; *D*, Schrader valve; *E*, platinum filament; *F*, electrical connexions; *G*, collar; *H*, crucible.

The lower section (*B*) has a flat base for standing on a bench. Oxygen is admitted through a connexion (*C*) on the side of the base and pressure is released through a Schrader valve (*D*) mounted opposite. These features are shown in the elevation on the left in Fig. 1. A platinum filament (*E*) is heated by means of an electric current passing through connexions (*F*) on the lower part of the bomb, as shown in the elevation on the right in Fig. 1.

The two main parts of the bomb are held together by means of a brass-threaded collar (*G*) and the rubber 'O' ring provides a gas-tight seal.

Method of use

Samples for combustion are placed in a silica crucible (*H*) of 5 ml capacity located horizontally by a ring and vertically by a plate beneath it, as shown in the elevation on the right in Fig. 1. Ignition is effected by means of a short length of cotton, one end of which is tied to the platinum filament and the other placed in contact with the sample.

The thermocouple is of copper-constantan, the junction being soldered to the tip of a spring-type wander-plug; the connecting wires pass down through a hole drilled through the spring, as shown in Fig. 2. The thermocouple is connected to a galvanometer through a series resistance, which is chosen to give full-scale galvanometer deflection for a rise in thermocouple temperature of about 50° .

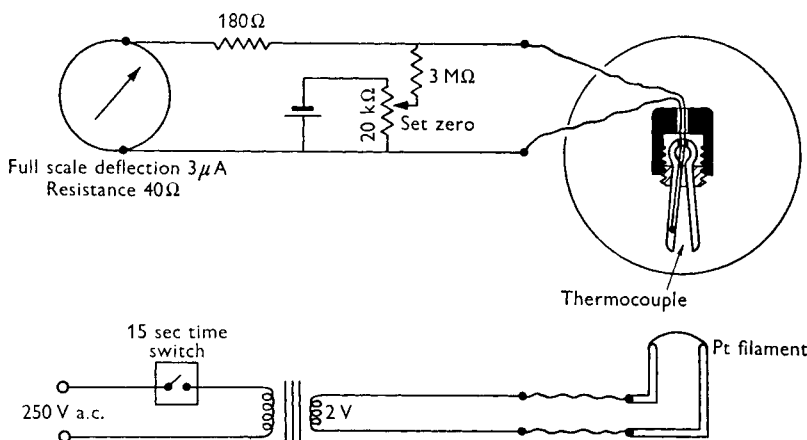

Fig. 2. Electrical circuits for firing mechanism and thermocouple.

The 'cold' junction formed by the constantan wire connexion to the galvanometer requires no temperature stabilizing, but must be carefully shielded from draughts. A battery and a variable resistance are provided for bringing the galvanometer to zero before each determination.

The current used to ignite the samples is controlled by means of a clockwork time switch, which operates for 15 sec, so that the heating effect of the ignition current is always the same. The temperature rise due to it and to the burning of the cotton fuse is determined separately, and subtracted as a 'blank' from the peak galvanometer reading.

On combustion of a sample, the temperature of the bomb in the region of the thermocouple rises rapidly to a peak value and then falls off, rapidly at first as heat is conducted away through the walls, and then more slowly. The peak value and the shape of the cooling curve are influenced by the distance of the crucible from the top. When the crucible is near the top, the peak value is highest and the cooling curve steepest, as shown by the upper curve in Fig. 3.

As the crucible is lowered, a greater proportion of the heat passes into the sides; thus the peak temperature is reduced and the cooling curve is modified by heat

flowing upwards from the sides; at the lowest position this flow caused a secondary peak, 2 or 3 min after the first. For reasons outlined on p. 506, a working distance of approximately 5.7 cm from the crucible base to the inside top was chosen.

In order to show that valid results can be obtained from widely differing materials, approximately equal weights of butterfat, benzoic acid, haemoglobin and starch were burned and the temperature curves plotted (Fig. 4). It may be seen that, in contrast to the heating curves at different crucible heights, the shapes of these curves were very similar and the temperature peaks occurred at the same time after ignition.

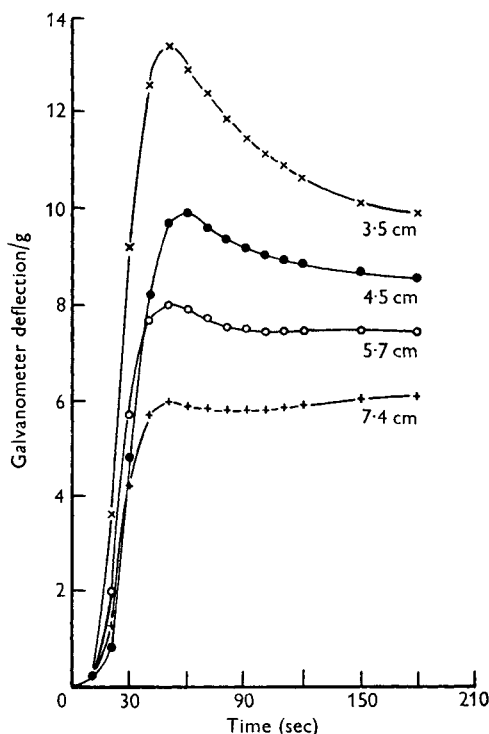

Fig. 3. Effect of variation of crucible position on heating curve. The distances indicated are measured from the base of the crucible to the inside top of the upper section of the bomb. The galvanometer deflections/g are not corrected for blank.

Six samples each of butterfat, benzoic acid, haemoglobin, starch, sucrose and urea were combusted; Fig. 5 shows the mean values of peak deflection/g material plotted against calorie values taken from tables. These points lie very close to a straight line. Table 1 shows the differences between the observed values (compared with those for benzoic acid Thermochemical Standard B.D.H., certified by the National Physical Laboratory) and the values given in the literature. Values are also given for some mixed diets. Thus it has been shown that, for materials having energy contents ranging from 2.5 to 9.3 kcal/g, the peak deflection/g is proportional to calorie value.

It was found that more reproducible results were obtained with materials burned in the form of a powder, lightly pressed down in the crucible, than with pelleted

samples. Urea proved difficult to ignite in this way and was mixed with known amounts of sucrose before combustion. Benzoic acid was melted in the crucible and allowed to solidify, since combustion of the loose powder resulted in detonation.

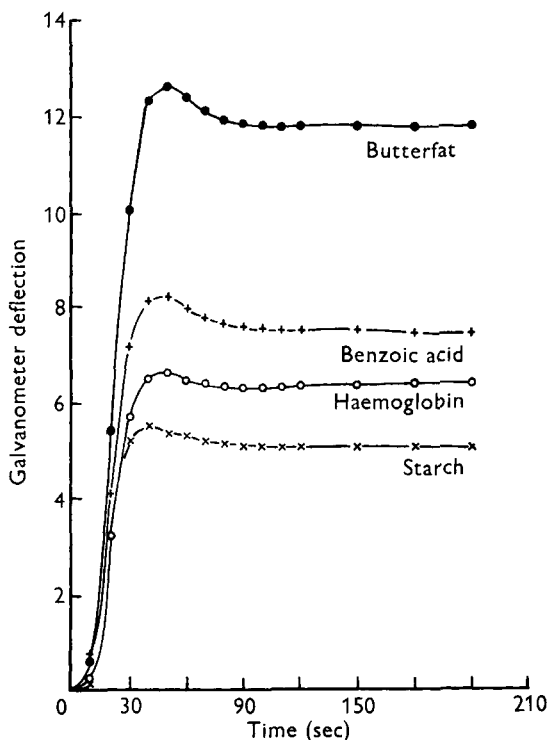

Fig. 4. Heating curves given by combustion of different materials.

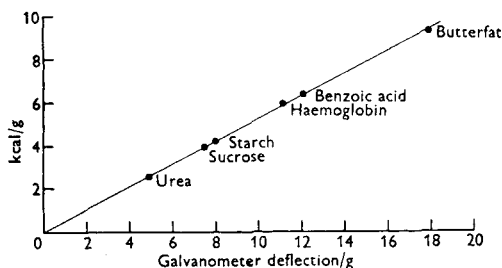

Fig. 5. Relationship between peak galvanometer deflection/g and the calorie value of six different materials.

Possible sources of error

Variations in oxygen pressure. Over the range 300–500 lb/in² the peak deflection/kcal liberated was found to be the same. Below 300 lb/in² the time taken to reach the peak temperature was extended and below 200 lb/in² combustion was obviously incomplete. For these reasons, and in accordance with other methods, 400 lb/in² (25 atm.) was selected for routine operation.

Table 1. *Calorie values of some materials determined in the ballistic bomb calorimeter with benzoic acid as a standard*

Material	Calorie value	
	Determined* (kcal/g)	From Hodgman (1953) (kcal/g)
Sucrose	3.91 ± 0.04	3.95
Butterfat	9.39 ± 0.06	9.30
Haemoglobin	5.83 ± 0.06	5.90
Starch	4.19 ± 0.04	4.18
Urea	2.57 ± 0.03	2.53
Diet 3	4.72 ± 0.04	—
Diet 13	5.37 ± 0.09	—
Diet J	4.13 ± 0.06	—

* Mean value of six replicates with its standard error.

Variations in initial temperature. Since the peak galvanometer deflection is a measurement of temperature difference, it seemed unlikely that small variations in initial temperature would be a source of error. For normal use the initial temperature of the bomb casing was about 20°. When samples were being combusted at short intervals it was achieved by cooling with tap water. The peak deflection/kcal was measured when the initial temperature was as high as 40° and was found to have risen by only 1.8%, although this measurement was made difficult by drift in the initial galvanometer reading.

Variation of crucible height. The effect of variations in crucible height on the heating curves has been discussed (p. 503). In the choice of the operating height a number of factors was considered. High positions gave higher peak temperatures, but the variations between replicates were greater. Low positions did not give curves with well-defined peak deflections (see Fig. 3). As discussed on p. 501, large temperature changes are advantageous, but it is shown in Table 2 that the effect of change of crucible height is greatest when the distance from the top is least. This factor could be a source of error caused by variations in crucible location, sample size, and from crucible to crucible, and is a probable explanation of the greater variation between replicates at the higher levels. The operating position of 5.7 cm was chosen as a compromise.

Because of the influence of sample height on deflection/kcal, it is evident that the volume of sample and standard should be similar, which in general can be achieved by taking the same weight. However, the magnitude of this effect at the chosen operating height of crucible was found to be an increase of only 2.5% of the peak deflection for an increase of 50% in the sample size. Similarly, variations in crucibles could be a source of error; with the same crucible, six determinations gave a standard error of 0.037 kcal, whereas with six different crucibles and the same material a standard error of 0.061 kcal was obtained.

Table 2. *Effect of crucible position in the ballistic bomb calorimeter on the peak galvanometer deflection/g sucrose combusted*

Crucible position* (a) (cm)	Deflection/g (b)	db/da †
7.4	5.50	-0.7
5.7	7.40	-1.5
4.5	9.55	-2.2
3.5	12.64	-3.5

* Distance from base of the crucible to the inside top of the upper section of the bomb.

† Change of galvanometer deflection/g/cm change of crucible position, obtained by measuring the slope of the tangents to the curve relating a to b .

DISCUSSION

By use of this method a technician with very little training can comfortably achieve the determination of calorie values at the rate of ten samples/h, including weighings. The apparatus is simple, robust, and very much cheaper than the conventional apparatus; only 2 or 3 ft of bench space in a general laboratory are required, as normal room temperature fluctuations have not been found to influence the results.

With the method described, an average value of $\pm 1\%$ is obtained for the standard error on six determinations. This accuracy is more than adequate for most purposes, especially if the difficulty of reducing sampling errors on mixed diets is borne in mind. The requirements for accuracy in the determination of calorie values in calorie balances has been reviewed by Blaxter (1956), who claims that errors greater than $\pm 0.5\%$ are undesirable for this purpose. If this assessment is valid, despite the large variations in biological experiments, such an order of accuracy may be achieved by the ballistic method if fifteen samples are combusted. Such a determination could be carried out in $1\frac{1}{2}$ h and would have the merit that sampling errors would be much reduced.

A different order of accuracy is required for the calorie values used in food surveys and dietetics, as is apparent from the use of arbitrary factors for the conversion of dubious analytical data into energy values (Morey, 1936). This type of assessment involves the determination of ether extract (assumed to be fat), nitrogen (protein assumed to be $6.25 \times N$), ash (assumed to have no calorie value) and fibre (!); the remainder is assumed to be carbohydrate. An alternative procedure involving fewer assumptions would be the determination of gross energy (G.E.) by direct calorimetry. It may be converted into digestible energy by multiplying by 0.95, a mean figure for a mixed diet (Atwater & Bryant, 1899). Metabolizable energy (M.E.) for human diets could then be assessed by subtracting a value for the loss of energy of the food when eaten, due to the inability of animals to oxidize nitrogen completely. The calorie value of urea/g nitrogen is 5.42 kcal, but this figure would not account for all the nitrogen compounds excreted. Rubner (1885), from work with dogs, suggested the factor of 7.45 kcal/g nitrogen resulting from body protein katabolism for these losses, and Atwater & Bryant (1899) suggested 1.25 kcal as the figure for urinary loss from 1 g

protein broken down in the body. The latter was determined on human subjects and is equivalent to 7.8 kcal/g absorbed nitrogen, which may be approximated to 7.5 kcal/g food nitrogen. Subtraction of this factor from the digestible energy gives the following equation:

$$\text{M.E./g} = (\text{G.E./g} \times 0.95) - (\text{N \%} \times 0.075).$$

A comparison between calorie values estimated by the two methods for some diets is given in Table 3.

Table 3. Comparison of different methods for calculating the metabolizable energy of some mixed diets

Diet	Metabolizable energy (kcal/g)		
	By analysis	By calorimetry	By balance*
J	—	4.1	4.0
2	4.9	4.8	—
3	4.6	4.7	—
4	4.8	4.7	—
6	4.7	4.7	—
8	4.8	4.7	—
10	4.8	4.7	—
12	4.5	4.6	—
13	5.0	5.0	—
14	5.0	4.8	—
16	4.3	4.4	—
18	5.0	5.0	—
40	4.8	4.7	—

* See Fox *et al.* (1959).

SUMMARY

1. A ballistic bomb calorimeter is described, which enables ten determinations to be carried out in an hour with an accuracy as good as with established methods. The characteristics of the bomb were investigated and the chosen operating conditions were at an oxygen pressure of 400 lb/in.², an initial temperature of 20°, a crucible position of 5.7 cm from the inside of the top of the bomb, and a sample weight of approximately 1 g.

2. An alternative method for the calculation of the metabolizable energy content of human foods is proposed, which involves fewer assumptions than with computation from data obtained by chemical analysis.

REFERENCES

- Atwater, W. O. & Bryant, A. P. (1899). *Rep. Storrs agric. Exp. Sta.* p. 73.
 Blaxter, K. L. (1956). *J. Dairy Sci.* **39**, 1401.
 Féry, C. M. (1912). *J. Phys. théor. appl.* 5th Ser. **11**, 550.
 Fox, H. C., Miller, D. S. & Payne, P. R. (1959). *Proc. Nutr. Soc.* **18**, ix.
 Hodgman, C. D. (editor) (1953). *Handbook of Chemistry and Physics*. Cleveland, Ohio: Chemical Rubber Publishing Co.
 Morey, N. B. (1936). *Nutr. Abstr. Rev.* **6**, 1.
 Raymond, W. F., Canaway, R. J. & Harris, C. E. (1957). *J. sci. Instrum.* **34**, 501.
 Rubner, M. (1885). *Z. Biol.* **21**, 250.